

S300SX-E

400-1100 HP Super-Core



FEATURES

- 360 degree thrust bearing
- Integrated speed sensor port
- Forged milled compressor wheel
- Flexible compressor cover outlet options
- Pre-machined boost port
- Optimized compressor stage aerodynamics

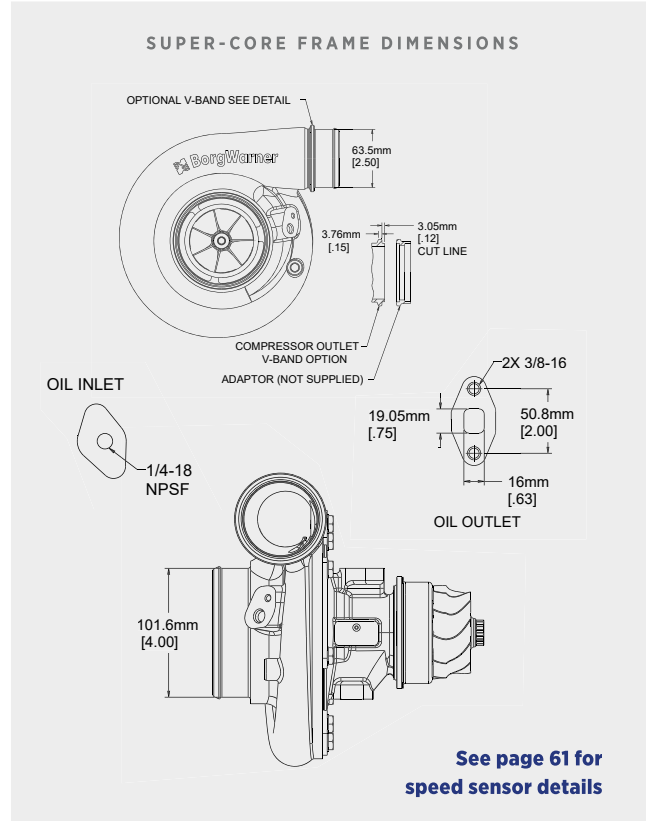

See page 61 for speed sensor details

Not included with turbo assemblies: Speed sensor, Turbine outlet V-Band, Drain port fitting

Super-Core Part #	Comp. Wheel O.D. (in)	Comp. Wheel O.D. (mm)	Comp Wheel Inducer Dia. (in)	Comp Wheel Inducer Dia. (mm)	Turbine Wheel O.D. (in)	Turbine Wheel O.D. (mm)	Turbine Wheel Exducer (in)	Turbine Wheel Exducer (mm)	Service Kit (360° thrust bearing)
13009097056	3.29	83.47	2.42	61.44	3.00	76.20	2.66	67.56	13007110005
13009097053	3.29	83.47	2.42	61.44	3.14	79.76	2.89	73.37	13007110005
13009097006	3.44	87.37	2.48	62.99	3.00	76.20	2.66	67.56	13007110005
13009097047	3.44	87.37	2.48	62.99	3.14	79.76	2.89	73.37	13007110005
13009097008	3.44	87.37	2.54	64.47	3.00	76.20	2.66	67.56	13007110005
13009097055	3.44	87.37	2.54	64.47	3.14	79.76	2.89	73.37	13007110005
13009097049	3.60	91.44	2.60	66.11	3.14	79.76	2.89	73.37	13007110005
13009097051	3.60	91.44	2.72	69.00	3.14	79.76	2.89	73.37	13007110005
NEW! 72mm 13009095091	3.58	91.00	2.83	72.00	3.14	79.76	2.89	73.37	13007110005

All turbine housing mounting hardware, clamp plates and cap screws included with Super-Core.

TURBINE HOUSING

Part #	A/R	Inlet Configuration	Notes
177211	0.88	Volute, Open Flow	80mm Turbine Wheel
177208	0.91	Volute, Twin Flow	
179905	1.00	Volute, Twin Flow	
177210	0.88	Volute, Open Flow	76mm Turbine Wheel
177207	0.91	Volute, Twin Flow	
177209	1.00	Volute, Twin Flow	



BEN BELCHER, GREEN BROTHERS RACING | S300SX

S300SX-E 400 - 775 HP Part #: 13009097053, 13009097056

Comp. Wheel Inducer Dia. (mm) 61.44
Comp. Wheel Outer Dia. (mm) 83.47

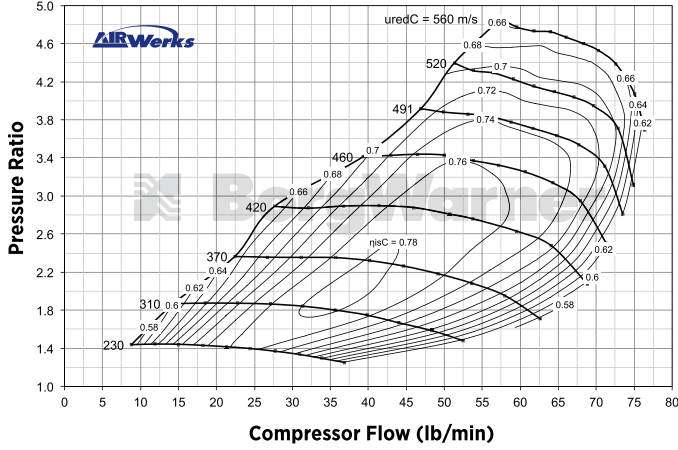

S300SX-E 500 - 875 HP Part #: 13009097049

Comp. Wheel Inducer Dia. (mm) 66.11
Comp. Wheel Outer Dia. (mm) 91.44

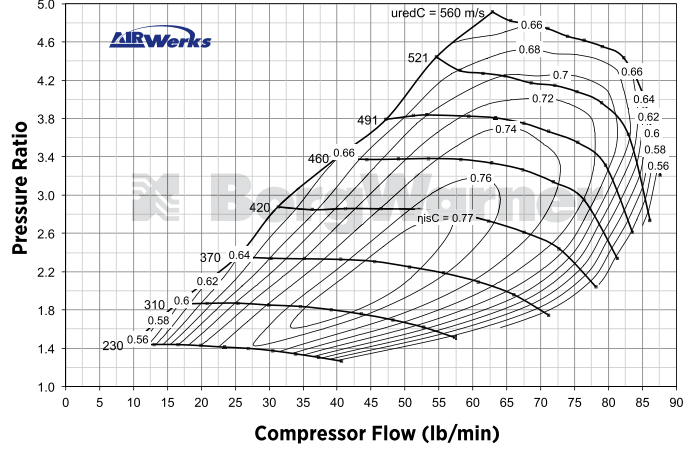

S300SX-E 450 - 785 HP Part #: 13009097006, 13009097047

Comp. Wheel Inducer Dia. (mm) 62.99
Comp. Wheel Outer Dia. (mm) 87.37

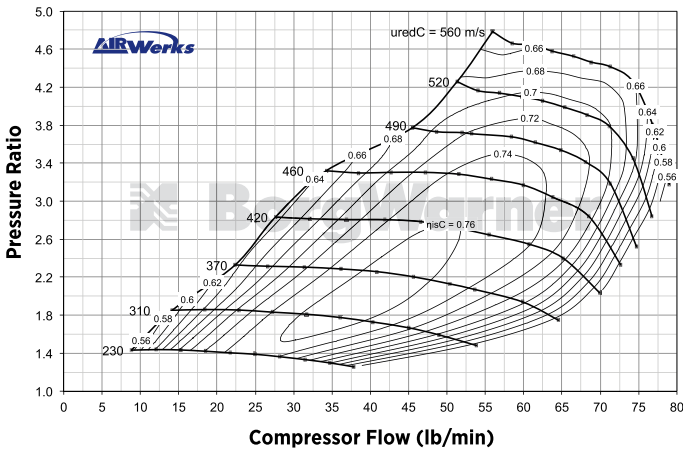

S300SX-E 500 - 1000 HP Part #: 13009097051

Comp. Wheel Inducer Dia. (mm) 69.00
Comp. Wheel Outer Dia. (mm) 91.44

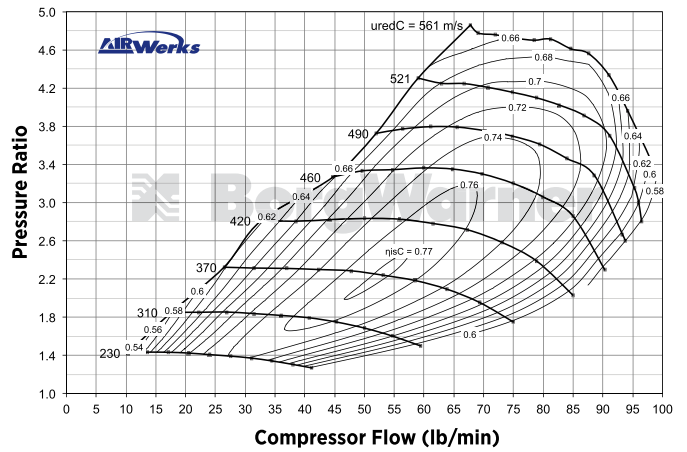

S300SX-E 450 - 825 HP Part #: 13009097008, 13009097055

Comp. Wheel Inducer Dia. (mm) 64.47
Comp. Wheel Outer Dia. (mm) 87.37

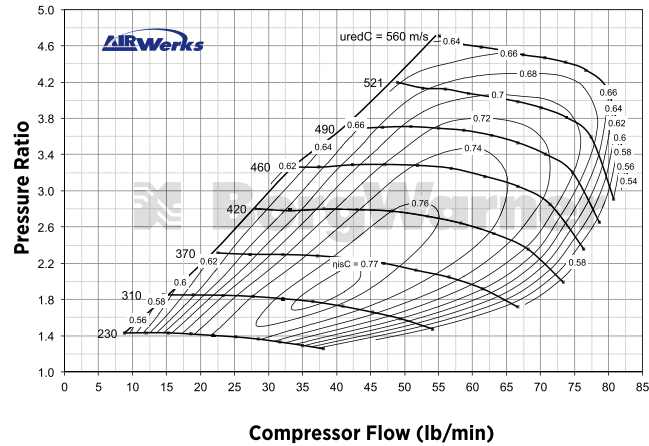

S300SX-E 500 - 1100 HP Part #: 13009095091

Comp. Wheel Inducer Dia. (mm) 72.00
Comp. Wheel Outer Dia. (mm) 91.00

