

GTW3884R

Horsepower: 450 - 950
Displacement: 2.0L - 6.0L

Honeywell

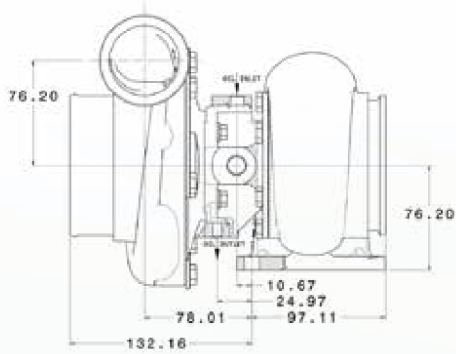

Measurements in MM



COMPRESSOR MAP

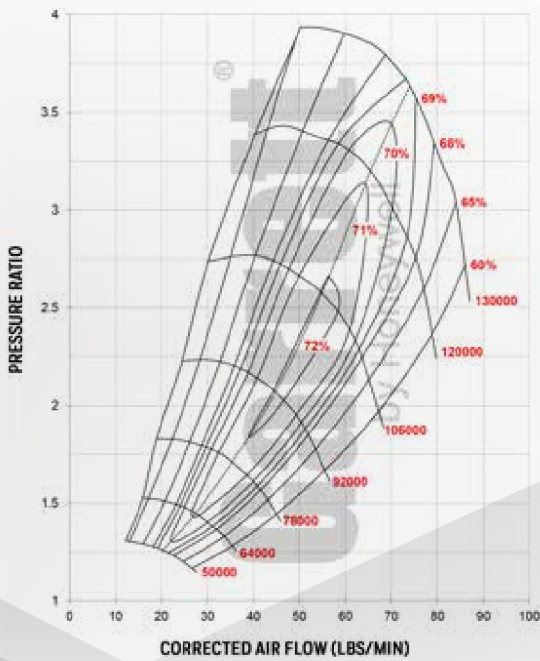

FEATURES:

- ◆ PORTED SHROUD DESIGN FOR SURGE RESISTANCE
- ◆ AVAILABLE IN BOTH JOURNAL BEARING AND BALL BEARING OPTIONS
- ◆ FORGED FULLY-MACHINED BILLET COMPRESSOR WHEEL
- ◆ INCONEL SUPER-ALLOY TURBINE WHEEL
- ◆ LIGHTWEIGHT ALUMINUM BACKPLATE

EXHAUST FLOW CHART

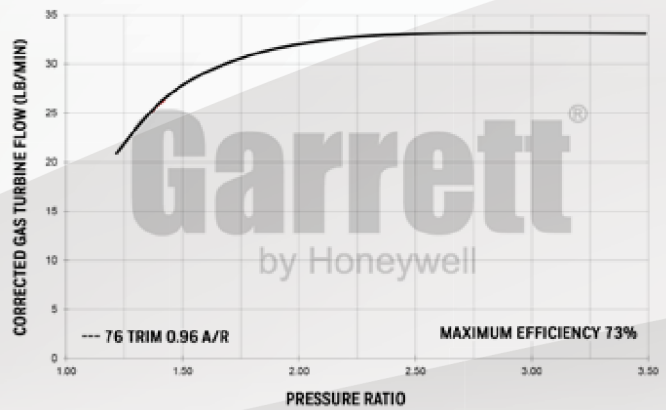

Super Core Reference Data		Compressor				Turbine		
Super Core PN	CHRA	Inducer	Exducer	Trim	A/R	Inducer	Exducer	Trim
841297-5003S	715582-0008	62mm	84mm	54	0.70	74mm	65mm	76
841297-5004S	715582-0009	64mm	84mm	58	0.70	74mm	65mm	76
841297-5005S	715582-0010	67mm	84mm	64	0.70	74mm	65mm	76
841691-5003S	757197-0012	62mm	84mm	54	0.70	74mm	65mm	76
841691-5004S	757197-0013	64mm	84mm	58	0.70	74mm	65mm	76
841691-5005S	757197-0014	67mm	84mm	64	0.70	74mm	65mm	76
Notes:		Turbine Kit PN	A/R	Inlet	Outlet	Wastegate	Divided	Trim
Super Core and Turbine Kit Sold Separately		844669-0009	0.96	T4	V-Band	Free Float	N	76
		844669-0010	1.14	T4	V-Band	Free Float	N	76

*841297 Journal Bearing Option
*841691 Water Cooled CHRA

Garrett
by Honeywell